

Investigating the Effect of Taheri Consciousness Fields on the Behavior of the Laser Light in Passing through an Aperture and Observing the Heisenberg Uncertainty Principle

Mohammad Ali Taheri¹, Firouz Payervand², Farzad Ahmadvanlou³, Sara Torabi⁴, Farid Semsarha^{5*}

1. Sciencefact R&D Department,
CosmoIntel Inc. Research Center,
Ontario, Canada

2. R&D Consultant, Tehran, Iran

3. Dept. of Mechanical and Aero-
space Engineering, University of
California Irvine, Irvine, CA, USA

4. Department of Plant Biology,
School of Biology, College of Sciences,
University of Tehran, Tehran, Iran

5. Institute of Biochemistry and
Biophysics (IBB), University of Tehran,
Tehran, Iran

* Corresponding author:

Farid Semsarha
Ph.D., Institute of Biochemistry and
Biophysics (IBB),
University of Tehran, P.O. Box: 13145-
1384, Tehran, Iran.

Email: Semsarha@alumni.ut.ac.ir

ABSTRACT

Investigating the behavior of light in the vicinity of an aperture and observing Heisenberg's uncertainty is a classic experiment in optics. Studies of Taheri Consciousness Fields (TCFs) include the study of different fields of physics in the systems under study. By applying a TCF to the system under the study, changes in the behavior of the system as a function of the Field are observed. The present study was performed with two aims: (a) Investigation of the effect of TCFs on the pattern of the laser light diffraction through an aperture (in Fraunhofer diffraction patterns). (b) Investigation of the effect of TCFs on the behavior of light and observation of Heisenberg's uncertainty principle in these conditions. Applying TCFs to the laser light-independent of the set-up experiment did not affect the light behavior. On the other hand, applying TCFs to the set-up of the light-passing test through an aperture has a significant effect on the light behavior in passing through the aperture. In such a way, the uncertainty and diffraction width in the state of treatment with TCFs is reduced compared to the control. This behavior is interpreted as reducing the effect of the observer in optics studies, where the aperture has been considered equivalent to an observer. In other words, this change in the light behavior as a result of applying the TCFs can be considered a process of direct observation (without intermediaries) of the system under the study using the TCF. This study indicates the high potential of the effects of TCFs on the known laws of physics, as an innovative tool in science.

Keywords: Taheri Consciousness Fields; direct observation; Fraunhofer diffraction; Heisenberg's uncertainty

INTRODUCTION

Werner Heisenberg developed a key piece of quantum theory, the Uncertainty Principle, in 1927 (Casidy, 1992). This principle became one of the most famous aspects of quantum mechanics. Before it had been thought that by knowing the exact position and momentum of a particle at any given time, one could predict its position and momentum at any time in the future. Contrary to this concept used in classical mechanics, Heisenberg found that the exact position and momentum of a particle are not predictable at the same time. In other words, according to the Uncertainty Principle, the more precisely the position of a particle is determined, the less precisely one can predict its momentum and vice versa (Hilgevoord and Uffink, 2001).

Before developing quantum mechanics, Thomas Young had investigated the wave behavior of light in 1801. At that time, it was assumed that light could behave as either wave or particle. However, modern physics demonstrated that light could, in fact, behave in both wave and particle manners. He passed light through two closely spaced parallel slits in a screen, and on the far side, observed several bright bands with the interference pattern. This result would not be expected if the light consisted of classical par-

ticles. With ordinary particles, the slits would act more like the stencils for spray paint, creating two specific bands (Ball, 2018).

The wave-particle duality is the concept in quantum mechanics that energy-carrying waves can behave like particles and that particles can also display a wave aspect. Richard Feynman presented several relevant experiments. Instead of the screen, he used a sensitive photo-detector in the double-slit experiment and reported that even with low enough intensity, so that only one photon is presented in the apparatus, diffraction can be observed. It seems that a single photon has interference with itself, and it must somehow travel through both slits. He also investigated electron diffraction with double slits. As shown in Figure 1, by covering up slit-1 and slit-2 separately, he recorded intensity distributions P_2 and P_1 , respectively. With a bright light source near the slits and detecting light bouncing off the electron, he could observe which slit the electron passes through. It was found that if an observer could tell which slit the electron went through, the intensity distribution would be $P_{12}=P_1+P_2$. In other words, the observation of the electron as it passes through the slit can change the resulting intensity distribution. This experiment is a vivid example that an observer can change the result of a quantum experiment (Branson, 2002; FRS, 2018).

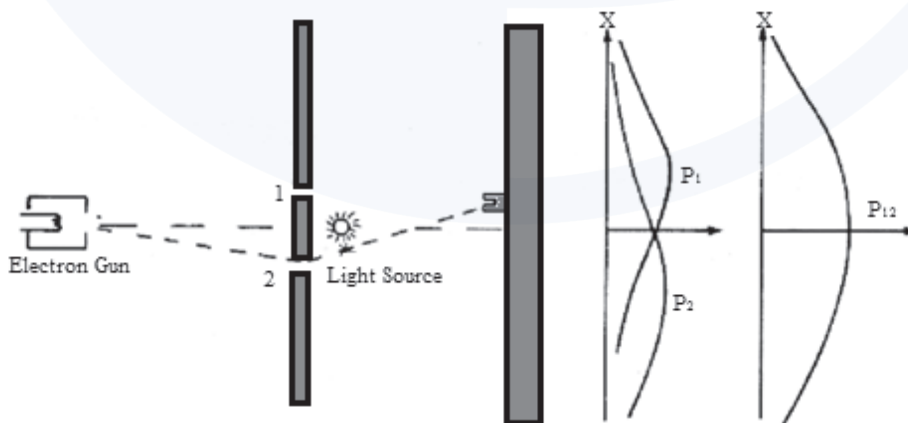

Figure 1: Observing the Electrons with Intense Light



Vol. 01
No. 04
April
2022

31

The First Journal in
Transcendental Research

Laser light diffraction pattern from an aperture

A diffraction pattern with a primary maximum and several secondary maxima is formed on the screen when a parallel monochromatic coherent beam of light with a wavelength much smaller than the aperture passes through the aperture with width d (Figure 2). The intensity in terms of a diffraction angle (α) according to Kirch-

hoff's diffraction formula is:

$$(1) \quad I(\alpha) = I(0) \cdot \left(\frac{\sin \beta}{\beta}\right)^2$$

where β is a parameter depends on the aperture width, diffraction angle and wavelength (λ):

$$(2) \quad \beta = \frac{\pi d}{\lambda} \cdot \sin \alpha$$

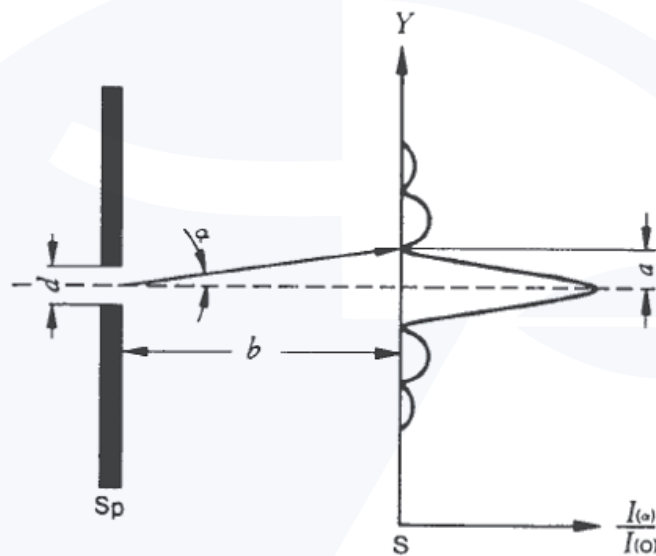

Figure 2. Fraunhofer diffraction over long distances

Heisenberg's uncertainty principle

Heisenberg's uncertainty principle states that two conventional correlated quantities, such as location and magnitude of motion, cannot be accurately measured simultaneously. Here, the uncertainty of the position y and the momentum p is defined by the standard deviation as follows:

$$(3) \quad \Delta y \cdot \Delta p \geq \frac{h}{4\pi}$$

(h is the Plank constant)

For a beam of photons, passing through the aperture with width d :

$$(4) \quad \Delta y = d$$

While the photons before the aperture move

only perpendicular to the plane of the aperture, i.e. in the x -direction, they will also have a component in the y -direction after the aperture. It is very convenient to take Δp_y to be equal to the difference between momenta in the first minimum and in the central maximum of the momentum distribution. For the first minimum of that distribution (Pašić et al., 2006):

$$(5) \quad \Delta p_y = \frac{h}{\lambda} \sin \alpha_1$$

On the other hand, according to Kirchhoff's diffraction formula, the angle of the first minimum, α_1 , can be calculated by,

$$(6) \quad \sin \alpha_1 = \frac{\lambda}{d}$$

Equations 4, 5, and 6 result in the following equation:

$$(7) \quad \Delta y \cdot \Delta p_y = h$$

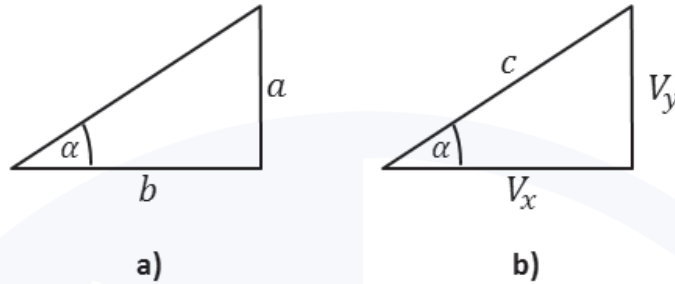

Figure 3. The geometry of diffraction from an aperture a) the trajectory and b) the velocity component of a photon

$$(8) \quad \tan \alpha_1 = \frac{a}{b}$$

Therefore, from a theoretical point of view and by insisting on performing a very simple set of experiments, as used for light diffraction, equation 6 can be written as follows (Pašić et al., 2006):

$$(9) \quad \frac{a}{\lambda} \sin \left(\arctan \frac{a}{b} \right) = 1$$

Equation 9 includes the Kirchhoff's diffraction formula explicitly and the Heisenberg's uncertainty criterion implicitly. Therefore, we refer to equation 9 as Kirchhoff-Heisenberg-Pasic Criterion in this paper.

Taheri Consciousness Fields

The nature of consciousness and its place in science has received much attention in the current century. Many philosophical and scientific theories have been proposed in this area. In the 1980s, Mohammad Ali Taheri introduced novel fields with a non-material/non-energetic nature named Taheri Consciousness Fields (TCFs). In this perspective, T-Consciousness is one of the three existing elements of the universe apart from matter

Equation 7 can be considered a derived criterion for a special case of Heisenberg's uncertainty principle.

In this experiment, the angle α_1 is obtained through the position of the first minimum (Figure 3).

and energy. According to this theory, there are various TCFs with different functions, which are the subcategories of a networked universal internet called the Cosmic Consciousness Network (CCN). The major difference between the theory of TCFs and other theoretical concepts about consciousness is related to the practical application of the TCFs. TCFs can be applied to all living and non-living creatures, including plants, animals, microorganisms, materials, etc.

Mohammad Ali Taheri, the founder of Erfan Keyhani Halqeh, a school of thought, introduced a new science in 2020 as a branch of this school. He coined the term Sciencefact for this new science because it utilizes scientific investigations to prove the existence of T-Consciousness as an irrefutable phenomenon and a fact. Although science focuses solely on the study of matter and energy and Sciencefact, by contrast, explores the effects of the [non-material/non-energetic] TCFs, Sciencefact has provided a common ground between the two by conducting reproducible laboratory experiments in various scientific fields, and it has used the scientific approach in proving TCFs.

The influence of the TCFs begins with the Connection between CCN as the Whole Taheri Consciousness of the universe and the subjects of



study as a part. This Connection called “Ettesal” is established by a Faradarmangar’s mind (a certified and trained individual who has been entrusted with the TCFs). The human mind has an intermediary role (Announcer) which plays a part by fleeting attention to the subject of study and then the main achievement obtained as a result of the effects of the TCFs. These fields cannot be directly measured by science, but it is possible to investigate their effects on various subjects through reproducible laboratory experiments (Taheri, 2013).

The research methodology in the study of T-Consciousness has been founded on the process of Assumption, Argument, and Proof, in which the basic Assumption is: The Cosmos was formed by a third element called T-Consciousness that is different from matter and energy.

The Argument: The existence of TCFs can be demonstrated by its effects on matter and energy (e.g., humans, animals, plants, microorganisms, cells, materials, etc.)

The Proof: is the scientific verification of the effects of TCFs on matter and energy (according to the Argument) through various reproducible scientific experiments.

Accordingly, to investigate and verify the existence, effects, and mechanisms of TCFs, the following five research phases (Phases 0 through 4), and the aims of each phase are outlined below.

Phase-0 studies aim to prove the existence of TCFs by observing their effects. The nature of T-Consciousness and what it is will not be addressed in this phase. Phase-1 explores the varied effects of different TCFs. Phase-2 examines the reason behind the varied effects of these fields. Phase-3 investigates the mechanism of TCFs effects on matter and energy. Finally, Phase-4 draws significant conclusions, particularly with regard to the mind and memory of matter and their relation to the T-Consciousness, etc.

Previously, investigation on distinction of Taheri Consciousness Fields from other physical fields (Taheri et al., 2021a) and the influence of TCFs on radioactivity phenomenon have been studied by the authors of the present study (Taheri et al., 2021b).

This study aimed to investigate the effect of the TCFs on the behavior of laser light in passing through the aperture and observing Heisenberg’s uncertainty principle.

Application of Taheri Consciousness Field

TCFs were applied to the samples according to the protocols regulated by the COSMOintel research center (www.COSMOintel.com). A request for Connection to the CCN to utilize TCFs can be placed through the COSMOintel website in the “Assign Announcement” section. This access is available for everyone at no cost. In order to study and experience this Connection, the researchers can register on the website at any time and in order to report the experiment to the COSMOintel research center. Certain details of the experiment must be provided to the center; for example, the characteristics or number and name of samples and controls must be specified. This entire experiment was carried out as a double-blind method where lab technicians were completely unaware of TCFs theory, and the Faradarmangar at the COSMOintel research center who established the Connection was unaware of the details of the study. Double-blind is a gold standard that is common in science experiments in the field of medicine and psychology, involving theoretical and practical testing.

In this study, two distinct TCFs, TCF type 1 (TCF₁) and TCF type 2 (TCF₂) were applied separately for one minute each on the laser light and the aperture-light setup throughout the experiment.

Materials

In the experiment, the following parts and equipment were employed according to Figure 4:

- He-Ne laser light source with a wavelength of 632.8 micrometers, 100 mW power, and 5 mm spot diameter

- Beam attenuator
- Apertures with 20 and 30 micrometers width
- Aperture holder
- Special optical base with a length of 500 mm
- Caliper with 0.1 mm resolution

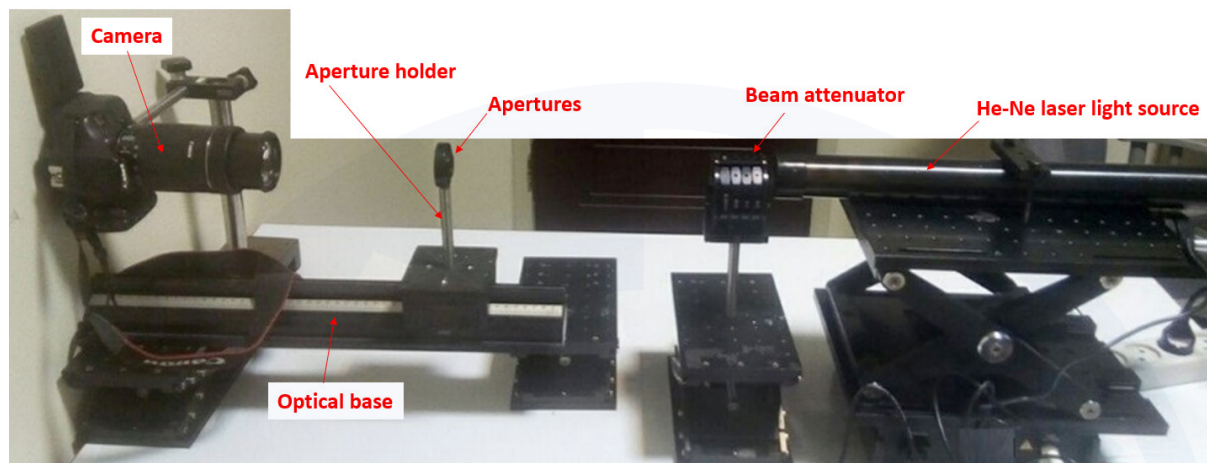

Figure 4. Experimental setup for measuring the intensity distribution of diffraction patterns

Methods

General conditions: apertures of different widths are placed in the path of the laser beam. The diffraction patterns formed by the apertures are measured for four different cases under four distinct boundary conditions: (1) Baseline, with no TCFs treatment, (2) laser light treatment under TCF1, (3) setup treatment under TCF1, and (4) laser light treatment under TCF2. In these experiments, recording the left minimum position, and the main right maximum position are sufficient to determine the diffraction angle. Finally, the momentum uncertainty is calculated using single-aperture diffraction patterns with different widths to observe Heisenberg's uncertainty principle.

Results

Apertures with widths of 20 and 30 micrometers are placed in the path of the laser beam. The diffraction patterns formed by the apertures are

presented on a screen (Figure 5). The position of the first minimum is measured by a caliper for all four cases with distinct boundary conditions. The experiment results are shown in Table 1.

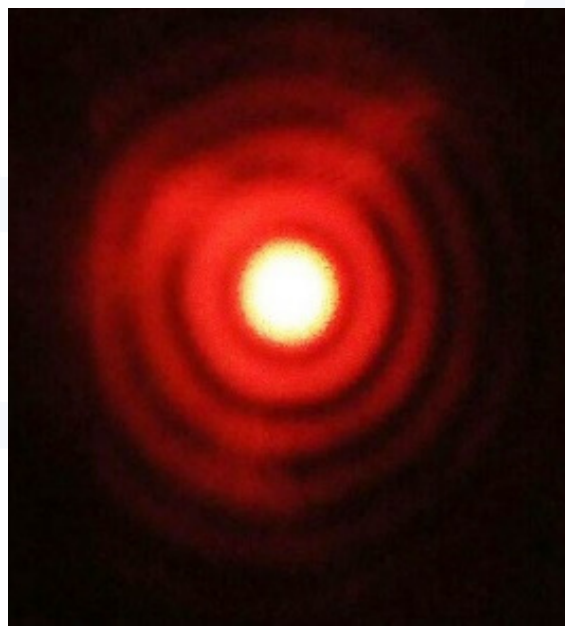

Figure 5. An example of diffraction patterns formed by apertures



Vol. 01
No. 04
April
2022

35

The First Journal in
T-Consciousness Research

Table 1. Test results for the state of application of TCFs, compared to the state of the control (without application of TCFs) in this study

Test condition	Aperture width	The first minimum parameters		Kirchhoff-Heisenberg-Pasic Criterion	Diffraction pattern broadening criterion
	<i>d (micron)</i>	<i>a (mm)</i>	<i>b (mm)</i>	$\frac{d}{\lambda} \sin(\arctan \frac{a}{b})$	$\frac{a}{b}$
Case 1 (baseline): without TCF treatment	30	6.3	400	0.7466	0.0158
	30	3.9	200	0.9243	0.0195
	20	11	255	1.3621	0.0431
	20	6.1	145	1.3284	0.0421
Case 2: with TCF ₁ treatment on the laser beam	30	4.4	250	0.8343	0.0176
	30	5.3	310	0.8104	0.0171
	30	6.8	400	0.8058	0.017
	30	3.7	200	0.8769	0.0185
	20	10	235	1.3437	0.0426
	20	6.3	145	1.3719	0.0434
	20	10.5	255	1.3003	0.0412
Case 3: with TCF ₁ treatment on test set up	20	6.1	145	1.3284	0.0421
	30	6.3	400	0.7466	0.0158
	30	3.2	200	0.7584	0.016
	20	5.4	145	1.1762	0.0372
Case 4: with TCF ₂ treatment on the laser beam	20	4.6	120	1.2107	0.0383
	30	6.5	400	0.7703	0.0163
	30	6.5	400	0.7703	0.0163
	30	3.5	200	0.8295	0.0175
	20	5.4	145	1.1762	0.0372
	20	5	120	1.3158	0.0417

The difference between the results in the measurement data of the Kirchhoff-Heisenberg-Pasic criterion (multiplication of the uncertainties of location and momentum) and the criterion of diffraction pattern broadening crite-

riion (ab) are shown in Tables 2 and 3. It is in order to determine the difference between the results in case 1 or baseline (without the application of TCFs) with cases 2, 3, and 4 (with the application of TCFs).

Table 2 . The difference between the results of the baseline (case 1) and the treatment cases for the Kirchhoff-Heisenberg-Pasic Criterion

Aperture width/ d (micron)	TCF ₁ treatment on laser beam (%)	TCF ₁ treatment on experiment set up (%)	TCF ₂ treatment on laser beam (%)
30	0.4309	9.9288	5.4362
20	0.6820	11.2841*	7.3778

* Validated by Anova: *p* value < 0.05

Table 3 . The difference between the results of the baseline (case 1) and the treatment samples for diffraction pattern broadening criterion (a/b)

Aperture width/ d (micron)	TCF ₁ treatment on laser beam (%)	TCF ₁ treatment on experiment set up (%)	TCF ₂ treatment on laser beam (%)
30	0.5666	9.9150	5.3824
20	0.6455	11.3850*	7.3944

* Validated by Anova: *p* value < 0.05

As can be understood from the detailed data in Tables 2 and 3, applying the TCF₁ to the experimental arrangement with the 20-micron aperture significantly reduces the Kirchhoff-Heisenberg-Pasic criterion and diffraction pattern broadening criterion by about 11%. However, the application of the TCF₁ and TCF₂ to the laser light has a less significant effect on the Kirchhoff-Heisenberg-Pasic criterion as well as the diffraction pattern broadening criterion. In addition, for a 30-micron aperture, the difference between the desired criteria, and the baseline is less significant based on the ANOVA test, and it indicates the low accuracy of the measurements in this case.

Discussion and Conclusion

Taheri Consciousness Fields have the ability to influence different levels of biological and physical systems. TCFs have different functions: according to Taheri's principles, the use of TCF₁ is a solution to achieve the optimal conditions of the system, and TCF₂ is used with the aim of achieving the program presented by the announcer, considering the facilities and conditions of the system under the study. The study of the effects of TCFs on the behavior of the light photons in passing through the aperture is a hugely challenging experiment in the study of specific and classical behavior of light and its diffraction. Also, measuring the Kirchhoff-Heisenberg-Pasic criterion in this behavior always gives certain values in routine physics laboratories. According to the findings of this experiment, the following conclusions can be made:

1. For the 20-micron aperture, the difference in the results for case 1 (baseline) as the control and case 3 (the treatment of TCF₁ on the test setup) is significant, for both the Kirchhoff-Heisenberg-Pasic criterion and diffraction pattern

broadening criterion. Therefore, the influence of the TCF on the experiment setup can be demonstrated.

2. The aperture in the present study is equivalent to the observer in quantum physics. The presence of an aperture (observer) in the path of light passage leads to broadening the diffraction pattern and increased uncertainty.

3. Reducing the Kirchhoff-Heisenberg-Pasic criterion and diffraction pattern broadening criterion of the 20-micron aperture, as a result of treating the TCF₁ on the experiment setup, indicates a reduction in the interaction between light and the aperture. In other words, the treatment of the experimental arrangement by the TCF₁ has led to a reduction of the aperture (observer) effect.

4. Another interpretation that can be offered about the TCF treatment is observation with less observer effect on the nature of the observed system (direct observation). This is because the TCF₁ treatment of the experimental setup has led to a significant reduction in the amount of measured Kirchhoff-Heisenberg-Pasic criterion compared to the control mode for the 20-micron aperture.

Based on these results and considering the previous studies done by the authors, TCFs have a unique ability to influence the system under the study in such a way that its behavior changes according to specific rules and based on the nature of the system under the study. These behaviors can be measured and examined in laboratories under standard conditions. The results on the behavior of light and reducing the amount of the Kirchhoff-Heisenberg-Pasic criterion in the passage through the aperture indicate the possibility of observing specific and intriguing changes in the behavior of matter and energy under the influence of TCFs. Given the reproducibility of the application of TCFs, we suggest that other researchers conduct studies on the behavior of light under the influences of TCFs.



Vol. 01
No. 04
April
2022

37

References

- Cassidy, D. C. (1992). *Uncertainty. The life and science of Werner Heisenberg*. New York: Freeman.
- Uffink, J. B., & Hilgevoord, J. (2001). The Uncertainty Principle. In E. N. Zalta (Ed.), *The Stanford Encyclopedia of Philosophy* (Winter ed.) <http://plato.stanford.edu/archives/win2001/entries/qt-uncertainty>.
- Hilgevoord, J., and Uffink, J. (2001). The uncertainty principle.
- Ball, P. (2018). Two slits and one hell of a quantum conundrum. *Nature*, 560(7717), 165-166.
- Branson, J. (2002). Quantum physics (UCSD Physics 130). Retrieved from https://quantummechanics.ucsd.edu/phi30a/130_notes.pdf.
- FRS, D. R. (2018). I Don't Understand Quantum Physics. Retrieved from https://www.southampton.ac.uk/~doug/quantum_physics/quantum_physics.pdf.
- Taheri M. A. (2013). *Human from Another Outlook* (2nd Edition). ISBN-13: 978-1939507006, ISBN-10: 1939507006.
- Taheri M. A., Payervand F., & Ahmadkhanlou F. (2021a). Distinction of Consciousness Fields According to Taheri from Other Conventional Physical Fields: Evaluating the Magnetic Properties of Materials, PREPRINT (Version 3) available at Research Square [<https://doi.org/10.21203/rs.3.rs-618789/v3>].
- Taheri, M. A., Payervand, F., Ahmadkhanlou, F., Torabi, S., & Semsarha, F. (2021). Investigation of the properties of Tc-99m radioisotope and water contaminated with Tc-99m under the influence of Consciousness Fields. Available at SSRN 3917935.
- Pašić, S., Gamulin, O., & Tocilj, Z. (2006). A simple experimental checking of Heisenberg's uncertainty relations. *Fizika A*, 15(2), 73-84.